



**Customer Contact Details**

Customer Name: _____	Shipping Name: _____
Advisor: _____	Shipping Address: _____
Address: _____	_____
_____	_____
_____	Phone: _____
Phone: _____	Email: _____
Email: _____	_____

**Additional Information**

Notes: _____	Current Wheelchair: _____
_____	Customer Weight: _____
_____	Customer Height: _____
_____	Customer Disability: _____

Guide:

- Base product
- Required option
- Optional Extra
- Critical Information
- Information Needed

**PRODUCT STYLE**

**SBCXZ011 VEYPR SUB4**  
\$21,987.00

**XA070** Open design

**Max User Weight 110kg (242lbs)**

**Yes, I am within the max user weight**

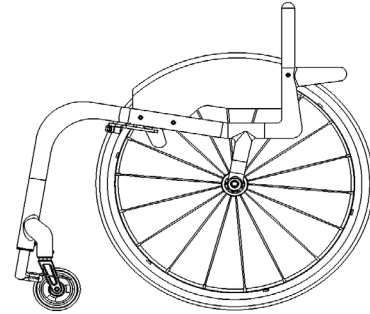

**CAD APPROVAL**

**XW012** QUOTE CAD drawing for approval  
\$550 FLAT FEE (includes two free revisions)

**XW010** ORDER CAD drawing for approval  
\$300 FLAT FEE (includes two free revisions)

**XW009** QUOTE only no CAD \$0

**XW011** ORDER only no CAD \$0

**KEY MEASUREMENTS**

**XY010** Seat width (Inside of sideguards)

**mm** (Max - 440mm)  
(Min - 250mm)

**XY020** Seat length

**mm** (Max - 440mm)  
(Min - 250mm)

**XY030** Extra seat length (Provides additional leg support & hand grip)

**mm** (Max - 460mm total seat)

**XY050** Front frame height

**mm** (Max - 520mm)  
(Min - 380mm)

**XY060** Rear frame height

**mm** (Max - 500mm)  
(Min - 380mm)

**XY070** Frame length

**mm** (Min = XY020 + XY030 + 140mm)  
(Max - 625mm)

**XY072** Caster position

**mm**  
 Optimize measurements

**XA020** Ergonomic seat  
\$121.00

Specify length  
 **mm**

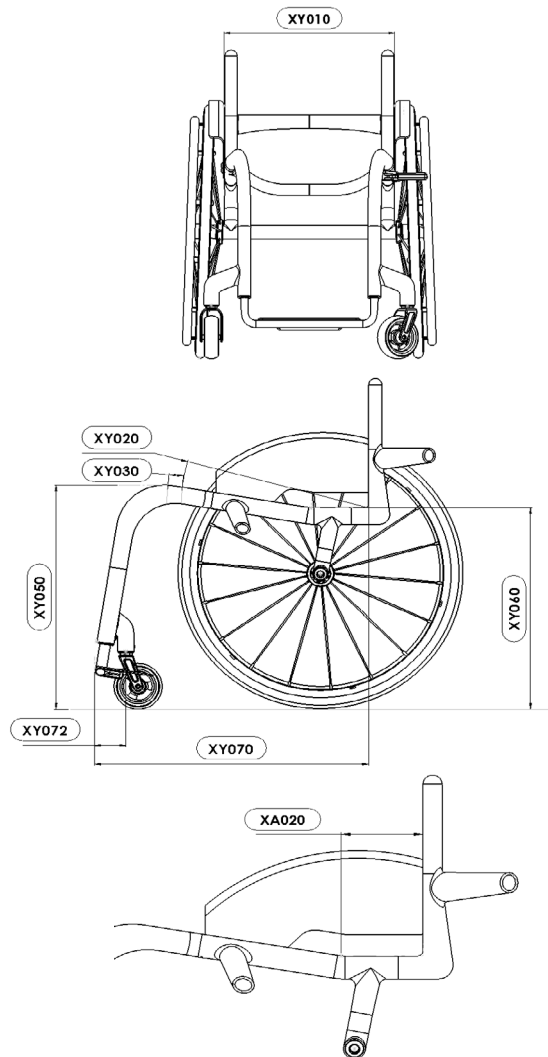

## FRONT FRAME AND FOOTREST

### Front Frame Options

XY080 Seat taper design

**i** Specify width  mm

*(When combined with XY091, dimension is inbetween the centre of the main bends)*

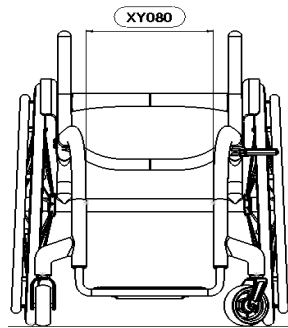

XY091 Parallel taper design

**i** Specify width  mm

*(When combined with XY080 dimensions must be smaller 20mm)*

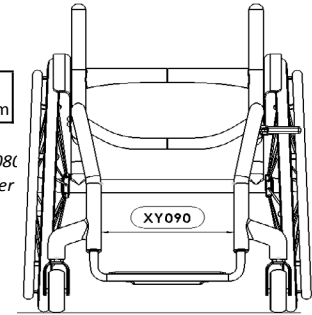

### Footrest Design (Choose one)

XY100 Round design

Caster Wheel Size	Max Height Achievable
4"	150

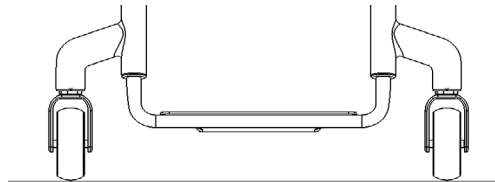

### Footrest Measurements

XY115 Front footrest height

**!**  mm

XY120 Rear footrest height

**i**  mm

*Std = 20 lower than front height*

XY125 Footrest length

**i**  mm

*Maximum length 120mm (Certified weight)*

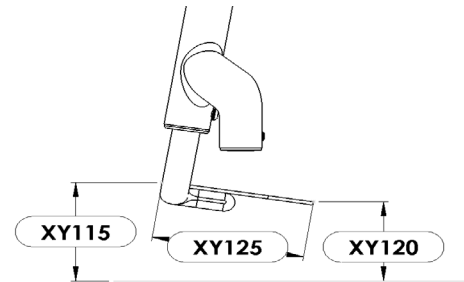

### Footrest Style

SBCXB400 Carbon Fibre Footrest with Carbon Plate  
*(Height adjustable +/-12mm)*

## CASTER WHEELS, FORKS & WHEEL LOCKS

### Caster Wheels

XC135 Aluminium centre 4"x1.25"  
Choose colour below:



- |  |   |
|--|---|
| <input type="checkbox"/> Silver hub & black tire (Std) | <input type="checkbox"/> Green hub & black tire |
| <input type="checkbox"/> Black hub & black tire        | <input type="checkbox"/> Red hub & black tire   |
| <input type="checkbox"/> Purple hub & black tire       | <input type="checkbox"/> Blue hub & black tire  |

### Caster Forks

XC192 Anti-Flutter Caster Fork

- |                                |                                 |                                 |
|--------------------------------|---------------------------------|---------------------------------|
| <input type="checkbox"/> Black | <input type="checkbox"/> Red    | <input type="checkbox"/> Silver |
| <input type="checkbox"/> Blue  | <input type="checkbox"/> Purple |                                 |

### Caster Pin Width

XY330 Caster pin width

Optimize measurements  
(Minimum width for clear caster rotation and maximum wheelbase length)

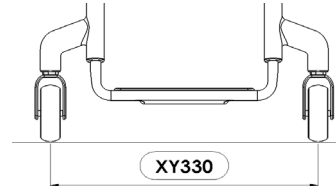

### Wheel Lock Options

SBCXD036 Compact scissor with lightweight fixing

XD010 Omit wheel locks

## SIDEGUARDS

### Sideguard without Fender

XE055 Screw on lightweight carbon fibre

### Sideguard Measurements

Individual above tire (Follow tire - max. 25mm)



mm

Level with tire (Follow tire)

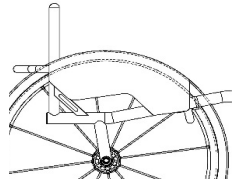

### Sideguard with Fender

XE065 Screw on lightweight carbon fibre w/fender

### Sideguard Measurements

10mm above tire (Standard)

Individual above tire (Min = 10mm)



mm

Centre of tire

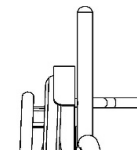
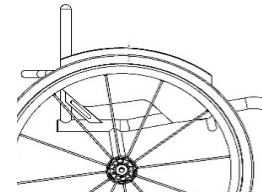

## BACKREST

### Backrest Height - Fixed

XY230 Backrest height

Specify height (400mm max)

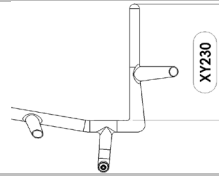

XG010 Fixed Backrest (non-folding)

### Ergonomic Options

XY360 Backrest angle

-5  -3  0  +3  +5

Individual  (Max -10/+20 Deg)

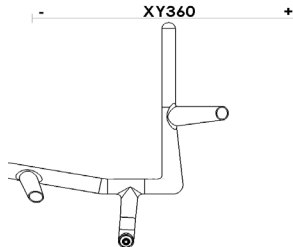

XG100 Ergonomic backrest \$146.00

Vertical height

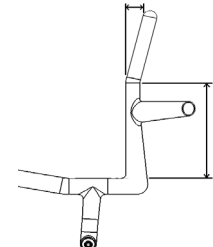

Rearward position

XG110 Inward taper (inside of backrest posts) \$146.00

Specify width or per side

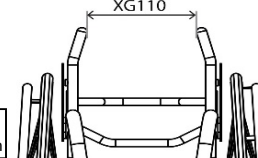

XG120 Outward flare (inside of backrest posts) \$146.00

Specify width or per side

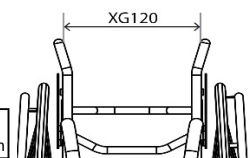

## CAMBER BAR

### Camber Angle

XY390 Camber angle

1  2  3

### Centre of Gravity

SBCXH100 Single post fixed centre of gravity (25-125mm)

Specify length

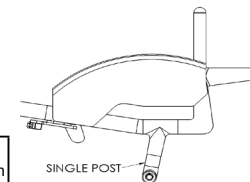

## FRAME FINISH OPTIONS

### Frame and Footrest

SBCXN300 Carbon Fibre Matte finish

SBCXN305 Carbon Fibre Gloss finish

### Accent Colour (Choose One)

**Note:** Accent colour includes decals only

Black  White  Purple  Grey

Red  Blue  Orange  Yellow

Pink  Green  None

SBCXN250 Individual Accent Colour \$189.00

## UPHOLSTERY

### Seat Upholstery

XP045 Sub4 Seat sling strap adjustable

### Backrest Upholstery

XP035 Airtech Sub4 backrest strap adjustable

XP050 Airtech backrest strap adjustable \*Non Sub4 option

### Backrest Upholstery Stitching Options

Silver (Std)  Black  Blue  Orange

Red  Purple

### Backrest Upholstery Logo Colour

White (Std)  Black  Blue  Individual:

Red  Purple

## REAR WHEELS (\* non certified weight options)

### Rear Wheel Size

- XY420 24" Wheels
  XY430 25" Wheels

### Rear Wheel Gap

- XY460 Rear wheel gap
 XY460
- 15
  20
  25

### Rear Wheel Options

- XK075 Spinery **BLXL** 18 blade spoke  
*(N/A with silver hub)*
 SBCXK150 Spinery **CLX** 18 carbon blade spoke
- XK226 Titanium 100mm quick release axle pins
 \$1,315.00 *(N/A with silver hub or colour rims)*

#### Spinery Colour Options:

- Black spokes
  White spokes
  Yellow spokes
  XK180 Individual spoke design  
*(Specify colour)*
- Red spokes
  Blue spokes
  Pink spokes
 *Inside:* \_\_\_\_\_
- Purple spokes
  Orange spokes
  Green spokes
 *Outside:* \_\_\_\_\_

#### Spinery Anodize Options

- XK190 Black hub  
NC *(std option)*
 XK201 Red hub/rims  
\$409.00 *(LX, XLX & BLXL only)*
 XK204 Gold hub/rims  
\$539.00 *(LX, XLX & BLXL only)*
 XK205 Individual hub/rims  
\$568.00 *Select colour:*
- XK202 Purple hub/rims  
\$409.00 *(LX, XLX & BLXL only)*
 XK203 Blue hub/rims  
\$409.00 *(LX, XLX & BLXL only)*

### Supply Without Wheels

- SBCXK040 Supply without Wheels

### Handrim Position / Options

- XY480 Narrow set handrim
  XY485 Wide set handrim
- XL090 Remove excess mounting tabs  
\$146.00 *(recommended for small wheel gaps)*

### Handrim Styles

- XL010 Aluminium hard anodized 6 tab
  XL040 Titanium 6 tab  
\$446.00
- XL160 Elipse 6 tab  
\$631.00 *(replacement for Surge)*
 XL050 Stainless steel 6 tab  
\$248.00
- XL020 Tetra grip 6 tab  
\$400.00
  RGK-XL140 Ergo gripp 6 tab wide  
\$691.00
- XL100 Para grip 6 tab  
\$400.00

### Tire Options

- XM060 Schwalbe One (Lightest option)  
\$133.00
- XM010 Kenda
 
 Grey
  Blue
  Red
- XM020 Schwalbe Marathon Plus  
\$98.00
  XM130 Kenda black  
\$28.00
- XM040 Shox solid airless  
\$160.00
  XM050 Kenda K885 mountain bike tire (24",25" only)  
\$40.00

### Inner Tube Valve Options

- XY500 Schraeder inner tube valve  
*(Standard if no option selected)*

 XY490 Presta inner tube valve

\* Indicates items that are not part of the certified weight of the Tiga Sub4

### CUSHION (\*\* non certified weight options)

#### Cushion foam options

- XP080 Cushion foam  
\$121.00  
*(select density and size below)*
- |  |  |   |
|--|--|---|
| <input type="checkbox"/> Soft (CMS040) | <input type="checkbox"/> Medium (CMS050) | <input type="checkbox"/> Hard (9lb recon) |
| <input type="checkbox"/> 50mm          | <input type="checkbox"/> 75mm            | <input type="checkbox"/> 100mm            |

#### Cushion cover upgrades

- XP085 Nylon cushion cover  
*(Black)*
- XP090 Airlite cushion cover  
\$98.00  
*(Black)*
- XP100 Leather cushion cover  
\$254.00  
*(Black)*

#### Jay Products

- JAY Cushion  
*(Price dependant on size / option)*
- JAY Backrest  
*(Price dependant on size / option)*

### ACCESSORIES (\*\* non certified weight options)

- XP120 Frame protectors Neoprene zip fasten (Black)  
\$83.00
- XP420 Frame protectors Nylon velcro fasten (Black)  
\$81.00
- XR010 Seat pouch velcro attach (Black)  
\$59.00
- XR200 Rucksack with RGK logo (Black)  
\$151.00
- XR020 Underseat large storage bag (Black)  
\$127.00
- XR090 Tool kit
- XS065 Sub4 Calf Strap

\*\* indicates options that, when chosen, will not enable RGK to guarantee a Sub4kg product weight



**OTHER (\*\* non certified weight options)**

Caster Wheel Size

XC140 Aluminium centre 5"x1.4"  
\$232.00 (Silver hub and black tire)

XC145 Aluminium centre 6"x1.4"  
\$310.00 (Silver hub and black tire)

Sideguards

XE030 Screw on aluminium, indicate size on page 4  
\$327.00

Push handle Options

XG080 Flip down push handles  
\$441.00

Anti-Tip Options

XJ100 Single sport anti tip  
\$504.00

Seat Plate

XR050 Carbon fibre seat plate  
\$480.00

Backrest Upholstery Leather Options (only with XP050)

XP070 Backrest upgrade to leather corners (Black)  
\$121.00 (only with Airtech upholstery XP050)

Backrest Accessories (only with XP050)

XP110 Backrest with zip pocket  
\$127.00

XP170 Individual backrest embroidery  
\$240.00 (Please provide .jpeg file and positioning)

\*\* indicates options that, when chosen, will not enable RGK to guarantee a Sub4kg product weight

**ADDITIONAL NOTES**

Grid area for additional notes.