

Breezy Series Wheelchair

User

Instruction

Manual &

Warranty

600 Series



I. INTRODUCTION

SUNRISE LISTENS

Thank you for choosing a Breezy wheelchair. We want to hear your questions or comments about this manual, the safety and reliability of your chair, and the service you receive from your supplier. Please feel free to write or call us at the address and telephone number below:

SUNRISE MEDICAL (US) LLC
Customer Service Department
2842 Business Park Ave.
Fresno, CA 93727
(800) 333-4000

Be sure to return your warranty card, and let us know if you change your address. This will allow us to keep you up to date with information about safety, new products and options to increase your use and enjoyment of this wheelchair. If you lose your warranty card, call or write and we will gladly send you a new one.

FOR ANSWERS TO YOUR QUESTIONS

Your authorized supplier knows your wheelchair best, and can answer most of your questions about chair safety, use and maintenance. For future reference, fill in the following:

Supplier: _____

Address: _____

Telephone: _____

Serial #: _____ Date/Purchased: _____

II. TABLE OF CONTENTS

I. INTRODUCTION	3
a. Sunrise Listens	3
II. TABLE OF CONTENTS	4
III. YOUR CHAIR AND ITS PARTS	6
IV. NOTICE - READ BEFORE USE	8
V. GENERAL WARNINGS	9
A. Weight Limit	9
B. Getting to Know Your Chair	9
C. To Reduce The Risk of an Accident	9
D. Safety Checklist	10
E. Changes & Adjustments	10
F. Environmental Conditions	10
G. Terrain	11
H. Street Use	11
I. Motor Vehicle Safety	11
J. When You Need Help	12
VI. WARNINGS: FALLS & TIP-OVERS	13
A. Center of Balance	13
B. Dressing or Changing Clothes	13
C. Obstacles	14
D. Reaching or Leaning	14
E. Moving Backward	15
F. Ramps, Slopes & Side Hills	16
G. Transfers	17
H. Curbs & Steps	18
I. Stairs	18
J. Escalators	18
VII. WARNINGS: FOR SAFE USE	19
A. Descending a Curb or Single Step	19
B. Climbing a Curb or Single Step	19
C. Climbing Stairs	20
D. Descending Stairs	20
E. Maintenance	20
VIII. WARNINGS: COMPONENTS & OPTIONS	22
A. Anti-Tip Tubes	22
B. Armrests	22
C. Cushion & Sling Seats	22

II. TABLE OF CONTENTS

D. Fasteners	23
E. Footrests	23
F. Pneumatic Tires	23
G. Positioning Belts	24
H. Power Drive	24
I. Push Handles	24
J. Quick-Release Axles	25
K. Rear Axles	25
L. Rear Wheel Locks	25
M. Modified Seat Systems	26
N. Upholstery Fabric	26
IX. CHAIR BASICS	27
A. To Mount & Remove Rear Wheels	27
B. To Fold & Unfold Chair	28
X. SET-UP AND ADJUSTMENTS	29
A. Set-up	29
B. Tools	29
C. To Find and Correct a Problem.....	30
D. Anti-Tip Tubes	30
E. Standard & Low Front Seat Heights	32
F. Caster Forks	33
G. Rear Wheel Locks	34
H. Flip-Back Armrests	35
I. Flip-Back Height Adjustable Armrests	35
J. Swing-Away Hangers & Footrests	36
K. Articulating Legrest & Elevating Legrest	37
L. Caster Plates	37
M. Caster Mounting	38
N. Backrest	38
XI. TROUBLESHOOTING	40
XII. MAINTENANCE	41
XIII. SUNRISE LIMITED WARRANTY	43

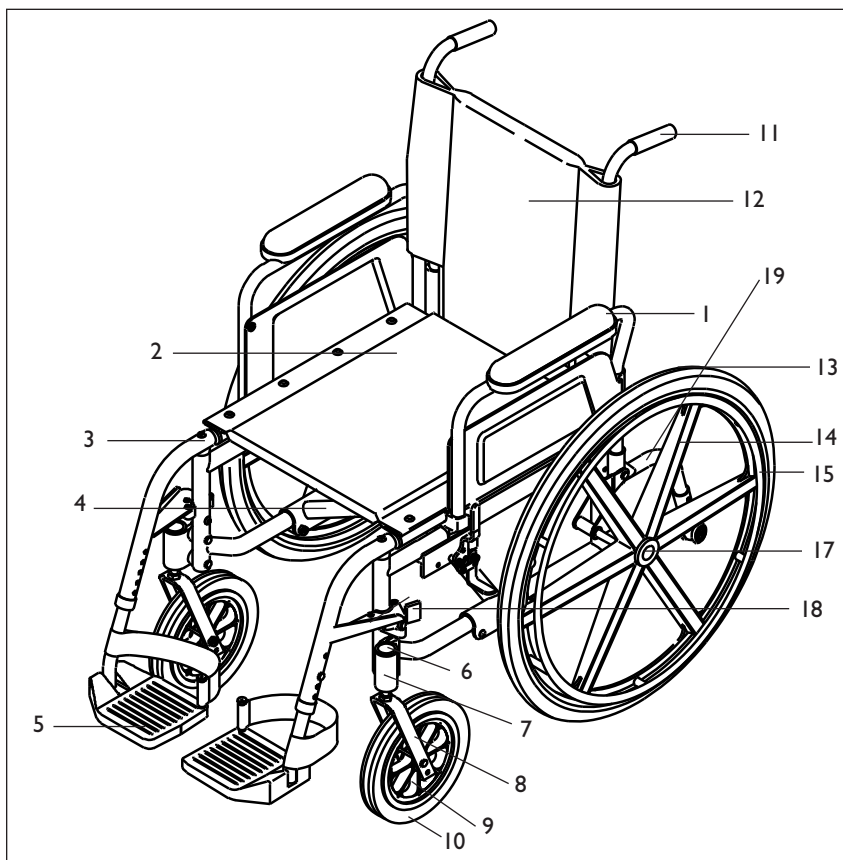

BREEZY 600

- | | |
|--|--|
| 1. Flip-back armrest | 11. Push handle backrest tube |
| 2. Padded seat sling | 12. Backrest |
| 3. Swing-away footrest | 13. 24" (540 mm) low-profile polyurethane tire |
| 4. Crossbrace | 14. 6-spoke mag wheel |
| 5. Flip-up composite footplate | 15. Composite handrim |
| 6. Caster housing dust cover | 16. Step-tube (not shown) |
| 7. Caster housing | 17. Threaded axle |
| 8. Caster fork | 18. Swing-away release latch |
| 9. Caster wheel | 19. Anti-tip tube (optional) |
| 10. 8" (203 mm) polyurethane caster tire | |

III. YOUR CHAIR AND ITS PARTS

Weight

28 lbs. (12.7 kg)

Adjustments

1" (25 mm) Vertical Axle- Adjustment,
2-Hole Fork Footrest Extension
Adjustment, Adjustable Caster
Housing, Backrest Adjustment

Colors

Blue, Silver Texture, Forest Green

Frame Dimensions

Seat Width - Std

14", 15", 16", 17", 18", 19", 20"

(356 mm, 381 mm, 406 mm, 432 mm,
457 mm, 483 mm, 508 mm)

Seat Depth

14", 15", 16", 17", 18"

(356 mm, 381 mm, 406 mm, 432 mm,
457 mm)

Backrest

16" - 19" (406 mm - 483 mm)

Hangers

60°, 70°, 90°

ELR, ALR

Footplates

Std - composite with heel loop

Opt - 90° Flip up

Ext. tubes - short, med., long

Casters

5", 6", 8" (127 mm, 157 mm, 203 mm)

Polyurethane & pneumatic

1 1/2" & 3/4" (38 mm & 19 mm)

caster fork stem

Axles/Axle Plate

Std - Offset Fixed

Opt - Quick-Release

Anti-Tip Tubes

Opt - Rear Anti-Tip Tubes

Rear Wheels

Type - mag

Sizes - 20", 22", 24"

Tires - Polyurethane

Pneumatic

Handrims

Std - composite, aluminum

Opt - plastic-coated

Projections Handrims

Opt - 8, 12 vertical or oblique

Wheel Locks

Std - High push-to-lock, High pull-
to-lock,

Opt - 6" (152 mm) extension
handles, grade aids

All features may not be available with some chair setups or in conjunction with another chair feature. Please consult your authorized supplier for more information.

A. CHOOSE THE RIGHT CHAIR & SAFETY OPTIONS

Sunrise provides a choice of many wheelchair styles to meet the needs of the wheelchair rider. However, final selection of the type of wheelchair, options and adjustments rests solely with you and your health care advisor. Choosing the best chair and set-up for your safety depends on such things as:

1. Your disability, strength, balance and coordination.
2. The types of hazards you must overcome in daily use (where you live and work, and other places you are likely to use your chair).
3. The need for options for your safety and comfort (such as anti-tip tubes, positioning belts, or special seating systems).

B. REVIEW THIS MANUAL OFTEN

Before using this chair you, and each person who may assist you, should read this entire manual and make sure to follow all instructions. Review the warnings often, until they are second nature to you.

C. WARNINGS

The word “WARNING” refers to a hazard or unsafe practice that may cause severe injury or death to you or to other persons. The “Warnings” are in four main sections, as follows:

1. V — GENERAL WARNINGS

Here you will find a safety checklist and a summary of risks you need to be aware of before you ride this chair.

2. VI — WARNINGS — FALLS & TIP-OVERS

Here you will learn how to avoid a fall or tip-over while you perform daily activities in your chair.

3. VII — WARNINGS — FOR SAFE USE

HERE YOU WILL LEARN ABOUT PRACTICES FOR THE SAFE USE OF YOUR CHAIR

4. VIII — WARNINGS — COMPONENTS & OPTIONS

Here you will learn about the components of your chair and options you can select for safety. Consult your authorized supplier and your health care advisor to help you choose the best set-up and options for safe use.

Note: Where they apply, you will also find “Warnings” in other sections of this manual. Heed all warnings in this section. If you fail to do so a fall, tip-over or loss of control may occur and cause severe injury to the rider or others.

A. WEIGHT LIMIT

 **WARNING**

NEVER exceed the weight limit of 250 pounds (113.6 kilograms), for combined weight of rider and items carried. If you do exceed the limit, damage to your chair, a fall, tip-over or loss of control may occur and cause severe injury to the rider or others.

B. GETTING TO KNOW YOUR CHAIR

 **WARNING**

Every wheelchair is different. Take the time to learn the feel of this chair before you begin riding. Start slowly, with easy, smooth strokes. If you are used to a different chair, you may use too much force and tip over. If you use too much force, damage to your chair, a fall, tip-over or loss of control may occur and cause severe injury to the rider or others.

C. TO REDUCE THE RISK OF AN ACCIDENT

 **WARNING**

1. BEFORE riding, you should be trained in the safe use of this chair by your health care advisor.
2. Practice bending, reaching and transfers until you know the limit of your ability. Have someone help you until you know what can cause a fall or tip-over and how to avoid doing so.
3. Be aware that you must develop your own methods for safe use best suited to your level of function and ability.
4. NEVER try a new maneuver on your own until you are sure you can do it safely.
5. Get to know the areas where you plan to use your chair. Look for hazards and learn how to avoid them.
6. Use anti-tip tubes unless you are a skilled rider of this chair and are sure you are not at risk to tip over.

If you fail to heed these warnings damage to your chair, a fall, tip-over or loss of control may occur and cause severe injury to the rider or others.

D. SAFETY CHECKLIST

 WARNING

Before Each Use Of Your Chair:

1. Make sure the chair rolls easily and that all parts work smoothly. Check for noise, vibration, or a change in ease of use. (They may indicate low tire pressure, loose fasteners, or damage to your chair).
2. Repair any problem. Your authorized supplier can help you find and correct the problem.
3. Check to see that both quick-release rear axles are locked. When locked, the axle button will “pop out” fully. If not locked, the wheel may come off and cause you to fall.
4. If your chair has anti-tip tubes, lock them in place.

Note: See “Anti-Tip Tubes” (Section VIII) for times you should not use them.

If you fail to heed these warnings damage to your chair, a fall, tip-over or loss of control may occur and cause severe injury to the rider or others.

E. CHANGES & ADJUSTMENTS

 WARNING

1. If you modify or adjust this chair, it may increase the risk of a tip-over UNLESS you make other changes as well.
2. Consult your authorized supplier BEFORE you modify or adjust your chair.
3. We recommend that you use anti-tip tubes until you adapt to the change, and are sure you are not at risk to tip over.
4. Unauthorized modifications or use of parts not supplied or approved by Sunrise may change the chair structure. This will void the warranty and may cause a safety hazard.

If you fail to heed these warnings damage to your chair, a fall, tip-over or loss of control may occur and cause severe injury to the rider or others.

F. ENVIRONMENTAL CONDITIONS

 WARNING

1. Use extra care if you must ride your chair on a wet or slick surface. If you are in doubt, ask for help.
2. Contact with water or excess moisture may cause your chair to rust or corrode. This could cause your chair to fail.
 - a. Do not use your chair in a shower, pool or other body of water. The chair tubing and parts are not water-tight and may rust or corrode from the inside.
 - b. Avoid excess moisture (for example, do not leave your chair in a damp bathroom while taking a shower).
 - c. Dry your chair as soon as you can if it gets wet, or if you use water to clean it.

If you fail to heed these warnings damage to your chair, a fall, tip-over or loss of control may occur and cause severe injury to the rider or others.

G. TERRAIN

 **WARNING**

1. Your chair is designed for use on firm, even surfaces such as concrete, asphalt and indoor floors and carpeting.
2. Do not operate your chair in sand, loose soil or over rough terrain.

This may damage wheels or axles, or loosen fasteners of your chair.

If you fail to heed these warnings damage to your chair, a fall, tip-over or loss of control may occur and cause severe injury to the rider or others.

H. STREET USE

 **WARNING**

In most states, wheelchairs are not legal for use on public roads. Be alert to the danger of motor vehicles on roads or in parking lots.

1. At night, or when lighting is poor, use reflective tape on your chair and clothing.
2. Due to your low position, it may be hard for drivers to see you. Make eye contact with drivers before you go forward. When in doubt, yield until you are sure it is safe.

If you fail to heed these warnings damage to your chair, a fall, tip-over or loss of control may occur and cause severe injury to the rider or others.

I. MOTOR VEHICLE SAFETY

 **WARNING**

Breezy wheelchairs do not meet federal standards for motor vehicle seating.

1. NEVER let anyone sit in this chair while in a moving vehicle.
 - a. ALWAYS move the rider to an approved vehicle seat.
 - b. ALWAYS secure the rider with proper motor vehicle restraints.
2. In an accident or sudden stop the rider may be thrown from the chair. Wheelchair seat belts will not prevent this, and further injury may result from the belts or straps.
3. NEVER transport this chair in the front seat of a vehicle. It may shift and interfere with the driver.
4. ALWAYS secure this chair so that it cannot roll or shift.
5. Do not use any chair that has been involved in a motor vehicle accident.

If you fail to heed these warnings damage to your chair, a fall, tip-over or loss of control may occur and cause severe injury to the rider or others.

J. WHEN YOU NEED HELP

 **WARNING****For The Rider:**

Make sure that each person who helps you reads and follows all warnings and instructions that apply.

For Attendants:

1. Work with the rider's doctor, nurse or therapist to learn safe methods best suited to your abilities and those of the rider.
2. Tell the rider what you plan to do, and explain what you expect the rider to do. This will put the rider at ease and reduce the risk of an accident.
3. Make sure the chair has push handles. They provide secure points for you to hold the rear of the chair to prevent a fall or tip-over. Check to make sure push handle grips will not rotate or slip off.
4. To prevent injury to your back, use good posture and proper body mechanics. When you lift or support the rider or tilt the chair, bend your knees slightly and keep your back as upright and straight as you can.
5. Remind the rider to lean back when you tilt the chair backward.
6. When you descend a curb or single step, slowly lower the chair in one easy movement. Do not let the chair drop the last few inches to the ground. This may damage the chair or injure the rider.
7. To avoid tripping, unlock and rotate anti-tip tubes up, out of the way. ALWAYS lock the rear wheels and lock anti-tip tubes in place if you must leave the rider alone, even for a moment. This will reduce the risk of a tip over or loss of control of the chair.

If you fail to heed these warnings damage to your chair, a fall, tip-over or loss of control may occur and cause severe injury to the rider or others.

A. CENTER OF BALANCE

 WARNING

The point where this chair will tip forward, back, or to the side depends on its center of balance and stability. How your chair is set up, the options you select and the changes you make may affect the risk of a fall or tip-over.

1. The Most Important Adjustments Are:
 - a. The position of the rear wheels. The more you move the rear wheels forward, the more likely your chair will tip over backward.
2. The Center Of Balance Is Also Affected By:
 - a. A change in the set-up of your chair, including:
 - The distance between the rear wheels.
 - The amount of rear wheel camber.
 - The seat height and seat angle.
 - Backrest angle.
 - b. A change in your body position, posture or weight distribution.
 - c. Riding your chair on a ramp or slope.
 - d. The use of a back pack or other options, and the amount of added weight.
3. To Reduce The Risk Of An Accident:
 - a. Consult your doctor, nurse or therapist to find out what axle and caster position is best for you.
 - b. Consult your authorized supplier BEFORE you modify or adjust this chair. Be aware that you may need to make other changes to correct the center of balance.
 - c. Have someone help you until you know the balance points of your chair and how to avoid a tip-over.
 - d. Use anti-tip tubes.

If you fail to heed these warnings damage to your chair, a fall, tip-over or loss of control may occur and cause severe injury to the rider or others.

B. DRESSING OR CHANGING CLOTHES

 WARNING

Your weight may shift if you dress or change clothes while seated in this chair. To reduce the risk of a fall or tip-over:

1. Rotate the front casters until they are as far forward as possible. This makes the chair more stable.
2. Lock anti-tip tubes in place. (If your chair does not have anti-tip tubes, back it up against a wall and lock both rear wheels).

If you fail to heed these warnings damage to your chair, a fall, tip-over or loss of control may occur and cause severe injury to the rider or others.

C. OBSTACLES

 **WARNING**

Obstacles and road hazards (such as potholes and broken pavement) can damage your chair and may cause a fall, tip-over or loss of control.

To avoid these risks:

1. Keep a lookout for danger – scan the area well ahead of your chair as you ride.
2. Make sure the floor areas where you live and work are level and free of obstacles.
3. Remove or cover threshold strips between rooms.
4. Install a ramp at entry or exit doors. Make sure there is not a drop off at the bottom of the ramp.
5. To Help Correct Your Center Of Balance:
 - a. Lean your upper body FORWARD slightly as you go UP over an obstacle.
 - b. Press your upper body BACKWARD as you go DOWN from a higher to a lower level.
6. If your chair has anti-tip tubes, lock them in place before you go UP over an obstacle.
7. Keep both of your hands on the handrims as you go over an obstacle.
8. Never push or pull on an object (such as furniture or a doorjamb) to propel your chair.

If you fail to heed these warnings damage to your chair, a fall, tip-over or loss of control may occur and cause severe injury to the rider or others.

D. REACHING OR LEANING

 **WARNING**

If you reach or lean it will affect the center of balance of your chair. This may cause you to fall or tip over. When in doubt, ask for help or use a device to extend your reach.

1. NEVER reach or lean if you must shift your weight sideways or rise up off the seat.
2. NEVER reach or lean if you must move forward in your seat to do so. Always keep your buttocks in contact with the backrest.
3. NEVER reach with both hands (you may not be able to catch yourself to prevent a fall if the chair tips).
4. NEVER reach or lean to the rear unless your chair has anti-tip tubes locked in place.

5. DO NOT reach or lean over the top of the seat back. This may damage one or both backrest tubes and cause you to fall.
6. If You Must Reach Or Lean:
 - a. Do not lock the rear wheels. This creates a tip point and makes a fall or tip-over more likely.
 - b. Do not put pressure on the footrests.

Note: Leaning forward puts pressure on the footrests and may cause the chair to tip if you lean too far.

- c. Move your chair as close as you can to the object you wish to reach.
- d. Do not try to pick up an object from the floor by reaching down between your knees. You are less likely to tip if you reach to the side of your chair.
- e. Rotate the front casters until they are as far forward as possible. This makes the chair more stable.

Note: To do this: Move your chair past the object you want to reach, then back up alongside it. Backing up will rotate the casters forward.

- f. Firmly grasp a rear wheel or an armrest with one hand. This will help to prevent a fall if the chair tips.

If you fail to heed these warnings damage to your chair, a fall, tip-over or loss of control may occur and cause severe injury to the rider or others

E. MOVING BACKWARD

WARNING

Use extra care when you move your chair backward. Your chair is most stable when you propel yourself forward. You may lose control or tip over if one of the rear wheels hits an object and stops rolling.

1. PROPEL YOUR CHAIR SLOWLY AND SMOOTHLY.
2. IF YOUR CHAIR HAS ANTI-TIP TUBES, MAKE SURE TO LOCK THEM IN PLACE.
3. Stop often and check to be sure your path is clear.

If you fail to heed these warnings damage to your chair, a fall, tip-over or loss of control may occur and cause severe injury to the rider or others.

F. RAMPS, SLOPES & SIDE HILLS

 **WARNING**

Riding on a slope, which includes a ramp or side hill, will change the center of balance of your chair. Your chair is less stable when it is at an angle. Anti-tip tubes may not prevent a fall or tip-over.

1. Do not use your chair on a slope steeper than 10%. (A 10% slope means: one foot in elevation for every ten feet of slope length.)
2. Always go as straight up and as straight down as you can. (Do not “cut the corner” on a slope or ramp.)
3. Do not turn or change direction on a slope.
4. Always stay in the CENTER of the ramp. Make sure ramp is wide enough that you are not at risk that a wheel may fall over the edge.
5. Do not stop on a steep slope. If you stop, you may lose control of your chair.
6. NEVER use rear wheel locks to try to slow or stop your chair. This is likely to cause your chair to veer out of control.
7. Beware Of:
 - a. Wet or slippery surfaces.
 - b. A change in grade on a slope (or a lip, bump or depression). These may cause a fall or tip-over.
 - c. A drop-off at the bottom of a slope. A drop-off of as small as 3/4 inch can stop a front caster and cause the chair to tip forward.
8. To Reduce The Risk Of A Fall Or Tip-Over:
 - a. Lean or press your body UPHILL. This will help adjust for the change in the center of balance caused by the slope or side hill.
 - b. Keep pressure on the handrims to control your speed on a down slope. If you go too fast you may lose control.
 - c. Ask for help any time you are in doubt.
9. Ramps At Home & Work - For your safety, ramps at home and work must meet all legal requirements for your area. We recommend:
 - a. Width. At least four feet wide.
 - b. Guardrails. To reduce the risk of a fall, sides of ramp must have guardrails (or raised borders at least three inches high).
 - c. Slope. Not more than a 10% grade.
 - d. Surface. Flat and even, with a thin carpet or other non-skid material. (Make sure there is no lip, bump or depression.)
 - e. Bracing. Ramp must be STURDY. You may need bracing so ramp does not “bow” when you ride on it.
 - f. Avoid A Drop Off. You may need a section at the top or bottom to smooth out the transition.

If you fail to heed these warnings damage to your chair, a fall, tip-over or loss of control may occur and cause severe injury to the rider or others.

G. TRANSFER

⚠ WARNING

It is dangerous to transfer on your own. It requires good balance and agility. Be aware that there is a point during every transfer when the wheelchair seat is not below you. To Avoid A Fall:

1. Work with your health care advisor to learn safe methods.
 - a. Learn how to position your body and how to support yourself during a transfer.
 - b. Have someone help you until you know how to do a safe transfer on your own.
2. Lock the rear wheels before you transfer. This keeps the rear wheels from rolling.

Note: This will NOT keep your chair from sliding away from you or tipping.
3. Make sure to keep pneumatic tires properly inflated. Low tire pressure may allow the rear wheel locks to slip.
4. Move your chair as close as you can to the seat you are transferring to. If possible, use a transfer board.
5. Rotate the front casters until they are as far forward as possible.
6. If you can, remove or swing footrests out of the way.
 - a. Make sure your feet do not catch in the space between the footrests.
 - b. Avoid putting weight on the footrests as this may cause the chair to tip.
7. Make sure armrests are out of the way and do not interfere.
8. Transfer as far back onto the seat surface as you can. This will reduce the risk that the chair will tip or move away from you.

If you fail to heed these warnings damage to your chair, a fall, tip-over or loss of control may occur and cause severe injury to the rider or others.

H. CURBS & STEPS

 WARNING

1. Each person who helps you should read and follow the warnings “For Safe Use” (Section VII).
2. Do not try to climb or descend a curb or step alone UNLESS you are a skilled rider of this chair and:
 - a. You can safely do a “wheelie”; and
 - b. You are sure you have the strength and balance to do so.
3. Unlock and rotate anti-tip tubes up, out of the way, so they do not interfere.
4. Do not try to climb a high curb or step (more than 4 inches high) UNLESS you have help. Doing so may cause your chair to exceed its balance point and tip over.
5. Go straight up and straight down a curb or step. If you climb or descend at an angle, a fall or tip-over is likely.
6. Be aware that the impact of dropping down from a curb or step can damage your chair or loosen fasteners.

If you fail to heed these warnings damage to your chair, a fall, tip-over or loss of control may occur and cause severe injury to the rider or others.

I. STAIRS

 WARNING

1. NEVER use this chair on stairs UNLESS you have someone to help you. Doing so is likely to cause a fall or tip-over.
2. Persons who help you should read and follow the warnings “For Attendants” (p. 16), and the “For Safe Use” (Section VII).

If you fail to heed these warnings damage to your chair, a fall, tip-over or loss of control may occur and cause severe injury to the rider or others.

J. ESCALATORS

 WARNING

NEVER use this chair on an escalator, even with an attendant. If you do, a fall or tip-over is likely.

If you fail to heed these warnings damage to your chair, a fall, tip-over or loss of control may occur and cause severe injury to the rider or others.

 WARNING

Before you assist a rider, be sure to read the warnings “For Attendants” (p. 16) and follow all instructions that apply. Be aware that you will need to learn safe methods best suited to your abilities.

A. DESCENDING A CURB OR SINGLE STEP** WARNING**

Follow these steps to help a rider descend a curb or single step going **BACKWARD**:

1. Stay at the rear of the chair.
2. Several feet before you reach the edge of the curb or step, turn the chair around and pull it backward.
3. While looking over your shoulder, carefully step back until you are off the curb or stair and standing on the lower level.
4. Pull the chair toward you until the rear wheels reach the edge of the curb or step. Then allow the rear wheels to slowly roll down onto the lower level.
5. When the rear wheels are safely on the lower level, tilt the chair back to its balance point. This will lift the front casters off the curb or step.
6. Keep the chair in balance and take small steps backward. Turn the chair around and gently lower front casters to the ground.

If you fail to heed these warnings damage to your chair, a fall, tip-over or loss of control may occur and cause severe injury to the rider or others.

B. CLIMBING A CURB OR SINGLE STEP** WARNING**

Follow these steps to help the rider climb a curb or single step going **FORWARD**:

1. Stay behind the chair.
2. Face the curb and tilt the chair up on the rear wheels so that the front casters clear the curb or step.
3. Move forward, placing the front casters on the upper level as soon as you are sure they are past the edge.
4. Continue forward until the rear wheels contact the face of the curb or step. Lift and roll the rear wheels to the upper level.

If you fail to heed these warnings damage to your chair, a fall, tip-over or loss of control may occur and cause severe injury to the rider or others

C. CLIMBING STAIRS

 WARNING

1. Use at least two attendants to move a chair and rider up stairs.
2. Move the chair and rider **BACKWARD** up the stairs.
3. The person at the rear is in control. He or she tilts the chair back to its balance point.
4. A second attendant at the front firmly grasps a non-detachable part of the front frame and lifts the chair up and over one stair at a time.
5. The attendants move to the next stair up. Repeat for each stair, until you reach the landing.

If you fail to heed these warnings damage to your chair, a fall, tip-over or loss of control may occur and cause severe injury to the rider or others.

D. DESCENDING STAIRS

 WARNING

1. Use at least two attendants to move a chair and rider down stairs.
2. Move the chair and rider **FORWARD** down the stairs.
3. The person at the rear is in control. He or she tilts the chair to the balance point of the rear wheels and rolls it to the edge of the top step.
4. A second attendant stands on the third step from the top and grasps the chair frame. He or she lowers the chair one step at a time by letting the rear wheels roll over the stair edge.
5. The attendants move to the next stair down. Repeat for each stair, until you reach the landing.

If you fail to heed these warnings damage to your chair, a fall, tip-over or loss of control may occur and cause severe injury to the rider or others.

E. MAINTENANCE

 WARNING

1. Inspect and maintain this chair strictly per chart.
2. If you detect a problem, make sure to service or repair the chair before use.
3. At least once a year, have a complete inspection, safety check and service of your chair made by an authorized supplier.

If you fail to heed these warnings damage to your chair, a fall, tip-over or loss of control may occur and cause severe injury to the rider or others. For additional maintenance information see Section XII: Maintenance.

VII. WARNINGS: FOR SAFE USE

A. ANTI-TIP TUBES (OPTIONAL)

 WARNING

Anti-tip tubes can help keep your chair from tipping over backward in most normal conditions.

1. Sunrise Recommends Use Of Anti-Tip Tubes:
 - a. UNLESS you are a skilled rider of this chair and are sure you are not at risk to tip over.
 - b. Each time you modify or adjust your chair. The change may make it easier to tip backward. Use anti-tip tubes until you adapt to the change, and are sure you are not at risk to tip over.
2. When locked in place (in the “down” position) anti-tip tubes should be BETWEEN 1 1/2 to 2 inches (38 mm to 51 mm) off the ground.
 - a. If set too HIGH, they may not prevent a tip-over.
 - b. If set too LOW, they may “hang up” on obstacles you can expect in normal use. If this occurs, you may fall or your chair may tip over.
3. Keep Anti-Tip Tubes Locked In Place UNLESS:
 - a. You have an attendant; or
 - b. You have to climb or descend a curb, or overcome an obstacle, and can safely do so without them. At these times, make sure anti-tip tubes are up, out of the way.

If you fail to heed these warnings damage to your chair, a fall, tip-over or loss of control may occur and cause severe injury to the rider or others.

B. ARMRESTS

 WARNING

Armrests detach and will not bear the weight of this chair.

1. NEVER lift this chair by its armrests. They may come loose or break.
2. Lift this chair only by non-detachable parts of the main frame.

If you fail to heed these warnings damage to your chair, a fall, tip-over or loss of control may occur and cause severe injury to the rider or others.

C. CUSHIONS & SLING SEATS

 WARNING

1. Breezy sling seats and standard foam cushions are not designed for the relief of pressure.
2. If you suffer from pressure sores, or if you are at risk that they will occur, you may need a special seat system or a device to control your posture. Consult your doctor, nurse or therapist to find out if you need such a device for your well-being.

If you fail to heed these warnings damage to your chair, a fall, tip-over or loss of control may occur and cause severe injury to the rider or others.

D. FASTENERS

 WARNING

Many of the screws, bolts and nuts on this chair are special high-strength fasteners. Use of improper fasteners may cause your chair to fail.

1. **ONLY** use fasteners provided by an authorized supplier (or ones of the same type and strength, as indicated by the markings on the heads).
2. Over- or under-tightened fasteners may fail or cause damage to chair parts.
3. If bolts or screws become loose, tighten them as soon as you can.

If you fail to heed these warnings damage to your chair, a fall, tip-over or loss of control may occur and cause severe injury to the rider or others.

E. FOOTRESTS

 WARNING

1. At the lowest point, footrests should be **AT LEAST 2 1/2 INCHES (64 mm)** off the ground. If set too **LOW**, they may “hang up” on obstacles you can expect to find in normal use. This may cause the chair to stop suddenly and tip forward.
2. To Avoid A Trip Or Fall When You Transfer:
 - a. Make sure your feet do not “hang up” or get caught in the space between the footrests.
 - b. Avoid putting weight on the footrests, as the chair may tip forward.
3. **NEVER** lift this chair by the footrests. Footrests detach and will not bear the weight of this chair. Lift this chair only by non-detachable parts of the main frame.

If you fail to heed these warnings damage to your chair, a fall, tip-over or loss of control may occur and cause severe injury to the rider or others.

F. PNEUMATIC TIRES

 WARNING

Proper inflation extends the life of your tires and makes your chair easier to use.

1. Do not use this chair if any of the tires is under- or over-inflated. Check weekly for proper inflation level, as listed on the tire sidewall.
2. Low pressure in a rear tire may cause the wheel lock on that side to slip and allow the wheel to turn when you do not expect it.
3. Low pressure in any of the tires may cause the chair to veer to one side and result in a loss of control.
4. Over-inflated tires may burst.

If you fail to heed these warnings damage to your chair, a fall, tip-over or loss of control may occur and cause severe injury to the rider or others.

G. POSITIONING BELTS (OPTIONAL)

 **WARNING**

Use positioning belts ONLY to help support the rider's posture. Improper use of these belts may cause severe injury to or death of the rider.

1. Make sure the rider does not slide down in the wheelchair seat. If this occurs, the rider may suffer chest compression or suffocate due to pressure from the belts.
2. The belts must be snug, but must not be so tight that they interfere with breathing. You should be able to slide your open hand, flat, between the belt and the rider.
3. A pelvic wedge or a similar device can help keep the rider from sliding down in the seat. Consult with the rider's doctor, nurse or therapist to find out if the rider needs such a device.
4. Use positioning belts only with a rider who can cooperate. Make sure the rider can easily remove the belts in an emergency.
5. NEVER Use Positioning Belts:
 - a. As a patient restraint. A restraint requires a doctor's order.
 - b. On a rider who is comatose or agitated.
 - c. As a motor vehicle restraint. In an accident or sudden stop the rider may be thrown from the chair. Wheelchair seat belts will not prevent this, and further injury may result from the belts or straps.

If you fail to heed these warnings damage to your chair, a fall, tip-over or loss of control may occur and cause severe injury to the rider or others.

H. POWER DRIVE

 **WARNING**

Do not install a power drive on any Breezy wheelchair. If you do:

1. It will affect the center of balance of your chair and may cause a fall or tip-over.
2. It will alter the frame and void the warranty.

If you fail to heed these warnings damage to your chair, a fall, tip-over or loss of control may occur and cause severe injury to the rider or others.

I. PUSH HANDLES (OPTIONAL)

 **WARNING**

When you have an attendant, make sure that this chair has push handles.

1. Push handles provide secure points for an attendant to hold the rear of this chair, to prevent a fall or tip-over. Make sure to use push handles when you have an attendant.
2. Check to make sure push handle grips will not rotate or slip off.

If you fail to heed these warnings damage to your chair, a fall, tip-over or loss of control may occur and cause severe injury to the rider or others.

J. QUICK-RELEASE AXLES (OPTIONAL)

 **WARNING**

1. Do not use this chair UNLESS you are sure that both quick-release rear axles are locked. An unlocked axle may come off during use and cause a fall.
2. An axle is not locked until the quick-release button pops out fully. An unlocked axle may come off during use, resulting in a fall, tip-over or loss of control and cause severe injury to the rider or others.

If you fail to heed these warnings damage to your chair, a fall, tip-over or loss of control may occur and cause severe injury to the rider or others.

K. REAR WHEELS

 **WARNING**

A change in set-up of the rear wheels will affect the center of balance of your chair.

1. The farther you move the rear axles FORWARD, the more likely it is that your chair will tip over backward.
2. Consult your doctor, nurse or therapist to find the best rear axle set-up for your chair. Do not change the set-up UNLESS you are sure you are not at risk to tip over.
3. Adjust the rear wheel locks after you make any change to the rear axles.
 - a. If you fail to do so, the locks may not work.
 - b. Make sure lock arms embed in tires at least 1/8 inch (3 mm) when locked.

If you fail to heed these warnings damage to your chair, a fall, tip-over or loss of control may occur and cause severe injury to the rider or others.

L. REAR WHEEL LOCKS

 **WARNING**

Rear wheel locks are NOT designed to slow or stop a moving wheelchair. Use the only to keep the rear wheels from rolling when your chair is at a complete stop.

1. NEVER use rear wheel locks to try to slow or stop your chair when it is moving. Doing so may cause you to veer out of control.
2. To keep the rear wheels from rolling, always set both rear wheel locks when you transfer to or from your chair.
3. Low pressure in a rear tire may cause the wheel lock on that side to slip and may allow the wheel to turn when you do not expect it.
4. Make sure lock arms embed in tires at least 3/8 inch (10 mm) when locked. If you fail to do so, the locks may not work.

If you fail to heed these warnings damage to your chair, a fall, tip-over or loss of control may occur and cause severe injury to the rider or others.

M. MODIFIED SEAT SYSTEMS

 **WARNING**

Use of a seat system not approved by Sunrise may alter the center of balance of this chair. This may cause the chair to tip over.

1. Do not change the seat system of your chair UNLESS you consult your authorized supplier first.
2. Use of a seat system not approved by Sunrise may affect the folding mechanism of this chair.
3. Use of a seating system not provided by Sunrise is prohibited for transit use. If you fail to heed these warnings damage to your chair, a fall, tip-over or loss of control may occur and cause severe injury to the rider or others.

N. UPHOLSTERY FABRIC

 **WARNING**

1. Replace worn or torn fabric of seat and seat back as soon as you can. If you fail to do so, the seat may fail.
2. Sling fabric will weaken with age and use. Look for fraying or thin spots, or stretching of fabrics at rivet holes.
3. “Dropping down” into your chair will weaken fabric and result in the need to inspect and replace the seat more often.
4. Be aware that laundering or excess moisture will reduce flame retardation of the fabric.

If you fail to heed these warnings damage to your chair, a fall, tip-over or loss of control may occur and cause severe injury to the rider or others.

A. TO MOUNT & REMOVE REAR WHEELS

(QUICK RELEASE OPTION)

Note: Axle is not locked until:

- a. The quick-release button pops out fully. (Fig. A)
- b. The ball bearings are fully visible on the outside of the sleeve.

1. To Install Wheel:

- a. Depress quick-release button (1) fully. This will release tension on ball bearings at other end.
- b. Insert axle through hub of rear wheel.
- c. Keep pressure on button (1) as you slide axle (2) into axle sleeve (3).
- d. Release button to lock axle in sleeve. Adjust axle if it does not lock.
- e. Repeat steps on other side.

2. To Remove Wheel:

- a. Depress quick-release button (1) fully.
- b. Remove wheel by sliding axle (2) out of axle sleeve (3).
- c. Repeat steps on other side.

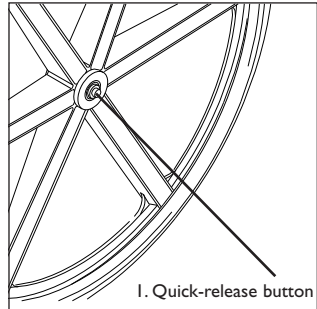
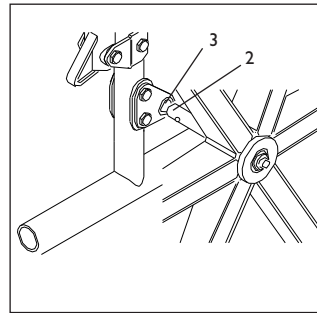

Figure A



B. TO FOLD & UNFOLD CHAIR

 **WARNING**

NEVER let your fingers come between the seat rail and the frame rail when you open or fold this chair. This may cause a pinch- or crush-type injury.

Note: You can remove quick-release wheels before you fold chair (and re-mount them before you unfold chair).

1. To Fold Chair:

- a. Make sure footrests are out of the way before you fold chair. (Swing-away, flip up or remove footrests.)
- b. Remove cushion (if any).
- c. Grasp center of seat sling and lift sharply until chair folds.

2. To Unfold Chair:

- a. Move to one side of chair. Check to make sure footrests do not interfere.
- b. Tilt chair toward you far enough to take the weight off the opposite wheel.
- c. Push down on the seat rail closest to you until chair opens fully.
- d. Make sure seat rail tubes snap into frame saddles.

A. SET-UP

1. Fasteners

 WARNING

Use of improper fasteners may cause the chair to fail. Over or under-tightened fasteners may fail or cause damage to chair parts. If bolts or screws become loose, tighten them as soon as you can.

- a. Many of the screws and bolts on this chair are special high-strength fasteners.
- b. Many nuts are the Nylock type. They have a plastic insert to help prevent loosening.
- c. **ONLY** use screws, bolts and nuts provided by an authorized supplier (or fasteners of the same type and strength, as indicated by the markings on the heads).

3. Washers & Spacers

- a. Make a note of the position of washers and spacers before disassembly.
- b. To avoid damage to the frame, position washers and spacers correctly when you reassemble parts.

Note on Torque Settings: A torque setting is the optimum tightening which should be made on a particular fastener. A torque wrench which measures in.-lbs should be used when tightening fastener on Breezy wheelchairs. Unless otherwise noted, use a torque setting of 50-65 in.-lbs. (5.6 -7.3 N·m) for all fasteners.

B. TOOLS

1. Basic Tool Kit

To set up, adjust and maintain your chair, you will need the following tools:

- a. 7/16" box and open-end wrench
- b. 1/2" box and open-end wrench
- c. 3/4" box and open-end wrench
- d. 1" socket wrench
- e. 5/32" Allen wrench
- f. 3/16" Allen wrench
- g. Phillips head screwdriver #2
- h. Custom axle wrench (or a 1/2" open-end wrench)

You can obtain a multi-purpose tool kit from Sunrise or buy the tools you need from a hardware store.

2. Torque Wrench

If you plan to adjust and maintain this chair yourself, Sunrise recommends that you use a torque wrench.

Note: A torque setting is the optimum tightening which should be made on a particular fastener.

A torque wrench which measures in.-lbs. should be used when tightening fasteners on Breezy wheelchairs. Unless otherwise noted, use a torque setting of 50-65 in./lbs. (5.6-7.3 N-m) when setting-up this wheelchair.

WARNING

When properly set up, your chair will roll smoothly and easily. All components should also work smoothly. If you detect a problem, be sure to correct it before using this chair.

C. TO FIND & CORRECT A PROBLEM

1. Review the TROUBLESHOOTING section to see if your chair has one of the listed symptoms. If so, follow steps to solve the problem.
2. Follow steps in this section to make sure set up is correct.
3. If steps 1 and 2 do not work, consult your authorized supplier for help.
4. If you still have a problem, contact customer service at 800.456.8165.

D. ANTI-TIP TUBES (Optional)

WARNING

Anti-tip tubes are recommended unless you are a skilled rider of this chair and are sure you are not at risk to tip over.

The following is recommended for all Breezy models except the 600 (listed next):

Note: When locked in place, anti-tip tube wheels should be between 1 1/2" to 2" (38 mm to 51 mm) off the ground. If set too high, they may not prevent a tip over. If set too low, they may "hang-up" and cause a fall or tip over.

1. To Install
 - a. Depress button (1) to draw second button (not shown) inside anti-tip tube (3).
 - b. Insert tube (3) into frame (4).
 - c. Rotate tube (3) until button (2) locks in place in mounting hole (not shown).

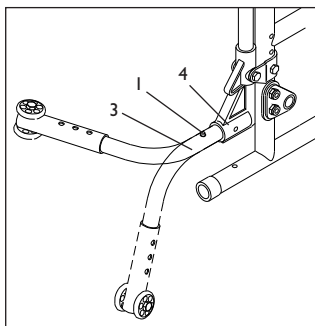

2. To Turn Anti-Tip Tube Up
 - a. Depress button (1) to draw second button (not shown) inside anti-tip tube (3).
 - b. Hold button in and turn anti-tip tube up. Release button.
 - c. Repeat with other side.

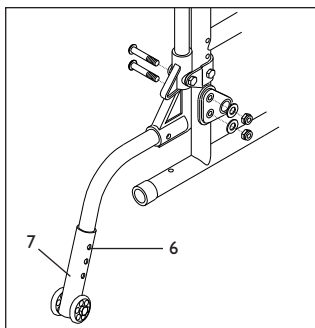

3. To Adjust Wheel Height
 - a. Depress button (6).
 - b. Raise or lower wheel tube (7) to one of three predrilled holes and lock it in place.
 - c. Raise or lower wheel tube (7) to one of three predrilled holes and lock it in place.

Note: You may need to use a longer or shorter wheel tube section to attain correct height of 1 1/2" to 2" (38 mm to 51 mm). You can obtain these from your authorized supplier.

BREEZY 600 SERIES

1. Inserting Anti-Tip Tubes Into Receiver
 - a. Press the rear anti-tip release lever on the anti-tip tube so that both release pins are drawn inside.
 - b. Insert into the anti-tip tube receiver.
 - c. Turn the anti-tip tube down until release pin is through the receiver mounting hole.
 - d. Insert second anti-tip tube the same way.

3. Turning Anti-Tip Tubes Up

Turn anti-tip tubes up when being pushed by attendant, overcoming obstacles or climbing curbs.

- Press the rear anti-tip tube release lever.
- Hold lever in and turn anti-tip tube up.
- Release lever.
- Repeat with second anti-tip tube.
- Remember to return anti-tip tubes to down position after completing maneuver.

E. STANDARD & LOW FRONT SEAT HEIGHTS

Note: Adjust seat height for body and mechanical efficiency. Be aware that a change in seat height may require a change in the size of the front caster stems or forks.

WARNING

- If you raise the seat too high, you may “out-adjust” the caster forks. If this occurs, the seat will tilt toward the front and may cause the rider to fall.
- To avoid this, you will need to use a longer caster fork or fork stem.

1. Adjustment

- For a standard 18 1/2” (470 mm) front seat height:
 - Remove the axle bolt.
 - Set axle in the bottom frame setting. Re-attach axle bolt and tighten.
 - Repeat steps on other side. Make sure both sides are the same height.
- For a low 17 1/2” (445 mm) front seat height:
 - Remove the axle bolt.
 - Set axle in the top frame setting. Re-attach axle bolt and tighten.
 - Repeat steps on other side. Make sure both sides are the same height.

Note: Use a torque setting of 150 to 175 in./lbs. (16.9-19.8 N·m) for axle nuts.

2. Seat Angle (not available on BREEZY 500)

If you change the seat height, make sure you adjust the front casters to attain the proper seat angle. (The seat should be slightly higher at the front.)

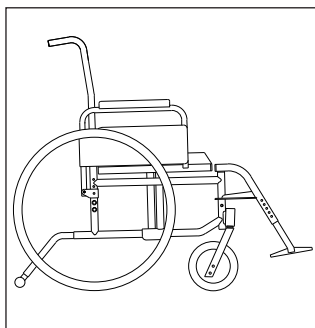

F. CASTER FORKS

Note: Two-hole caster forks allow you to adjust the seat height or seat angle.

- a. For a standard 18 1/2" (470 mm) front seat height:
 1. Remove caster wheel bolt (1) and bearing spacers (not shown).
 2. Move caster into the bottom fork position (2).
 3. Replace caster wheel bolt and bearing spacers. Tighten bolt.
 4. Repeat steps on other side. Make sure to adjust both the same.
- b. For a low 17 1/2" (445 mm) front seat height:
 1. Remove caster wheel bolt and bearing spacers (1).
 2. Move caster into the top fork position (3).
 3. Replace caster wheel bolt and bearing spacers. Tighten bolt.
 4. Repeat steps on other side. Make sure to adjust both the same.

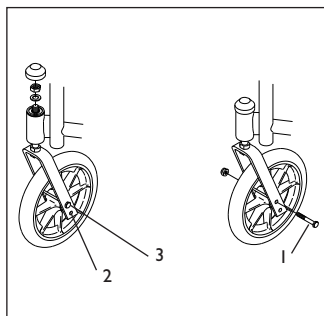

G. REAR WHEEL LOCKS

The Breezy Series wheelchairs come with wheel locks. We install wheel locks at the factory unless you request otherwise.

Note: Use a torque setting of 25-40 in./lbs.
(2.8-4.5 N·m) to tighten wheel lock bolts.

⚠ WARNING

Make sure lock arms embed in tires at least 1/8" (3 mm) when locked. If you fail to do so, the locks may not keep the rear wheels from rolling.

1. High-Mount Wheel Locks

(push-to-lock or pull-to-lock)

To install or adjust:

- a. Use an open-end wrench to loosen two bolts (1) on top clamp (2).
- b. Turn each bolt counter-clockwise one-quarter turn; then loosen each bolt two turns until you can remove both bolts. (Alternate, to keep bolts from binding.)
- c. Side clamp (2) toward rear wheel until lock arm (3) embeds in tire at least 1/8" (3 mm) when locked.
- d. Alternate as you retighten bolts (1).
- e. Repeat steps on other side.

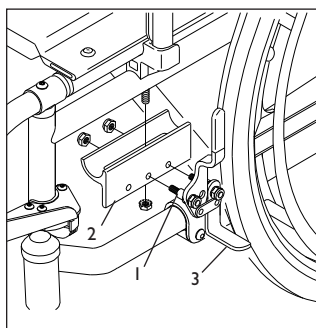

2. Wheel Locks - Quickie Style (Option)

Quickie style high-mount wheel locks are installed at Sunrise unless you have requested otherwise.

Note: Use a torque setting of 70-80 in./lbs.
(7.9-9.0 N·m) to tighten when setting up wheel locks.

To install or adjust high-mount wheel lock:

- a. Loosen the screws on the top of each clamp. Do not attempt to remove one screw at a time.

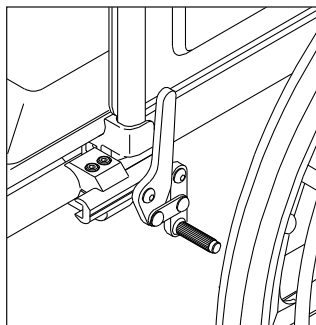

- b. Slide assembly toward rear wheel, until clamp embeds into tire, to prevent wheel movement when in locked position.

H. FLIP-BACK ARMRESTS

Note: Non-removable; we install this armrest at the factory.

I. FLIP-BACK HEIGHT ADJUSTABLE ARMRESTS (Optional)

Note: Armrest is removable; you can adjust the height of the armrest pad.

1. To Flip Armrest Back

Push latch lever (1) toward tube to “flip” or “tilt” armrest back.

2. Installation

- a. Tilt armrest back and insert rear arm tube (2) into receiver (3).
- b. Tilt armrest forward. This will engage pin to secure rear arm tube.
- c. Push armrest down until front tube locks in place.

3. Removal

- a. Push latch lever (1) toward tube.
- b. Tilt armrest back toward rear of chair.
- c. Pull up on armrest (pin holding armrest in rear tube will release).

4. Height Adjustment

- a. Pull back on upper lever (4) to release.
- b. Slide armrest up or down to chosen height.
- c. Release upper lever (4). Move armrest slightly to make sure it locks in place.

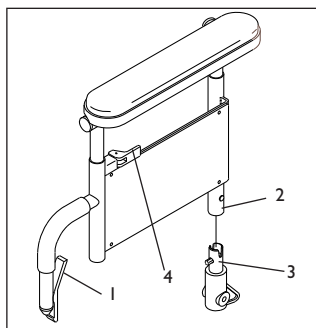
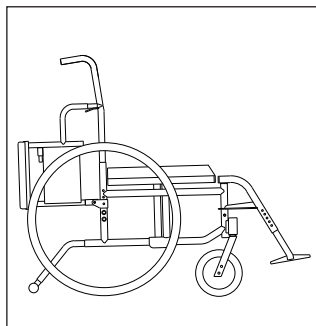
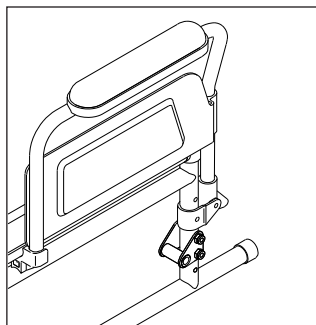

J. SWING-AWAY HANGERS & FOOTRESTS
(60° OR 70°)

1. Installation

- a. Place swing-away pivot saddle into the receiver on front frame tube with the footrest facing outward from the frame.
- b. Rotate the footrest inward until it locks into place on locking bolt.

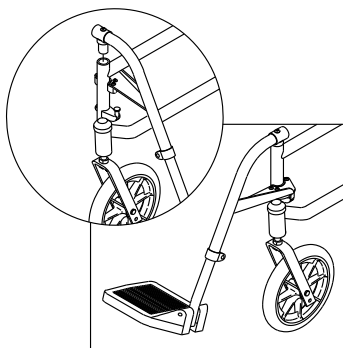

2. Removal

- a. To remove footrest, push release latch toward the frame.
- b. Rotate footrest outward and lift.

3. Height-Adjustment

- a. Remove retaining bolt in the frame tube.
- b. Slide footrest tubes up or down inside frame tube to desired height.
- c. Align predrilled holes in footrest and reinsert bolts.
- d. Tighten bolts.

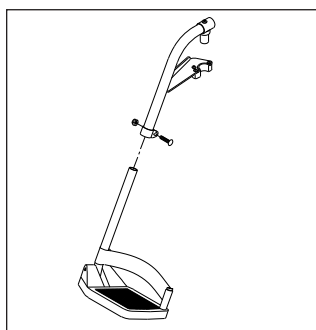

Breezy 500

4. Footplate Angle-Adjustment

- a. Loosen the retaining bolt in the frame tube.
- b. Reposition footplate to desired angle and re-tighten bolt.

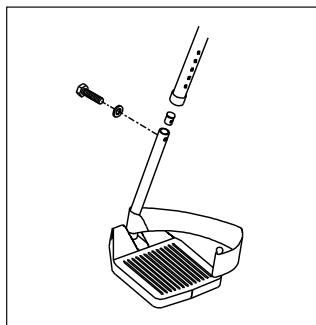

Breezy 510 & 600

K. ARTICULATING LEGREST & ELEVATING LEGREST (Optional)

1. Installation

- a. Follow same steps as for swing-away hangers and footrests. (p. 40)

2. Adjustment

- a. List legrest to chosen position. Legrest will lock in place.
- b. To lower legrest, press release lever (1) forward and lower legrest to chosen position. Legrest will lock in place.

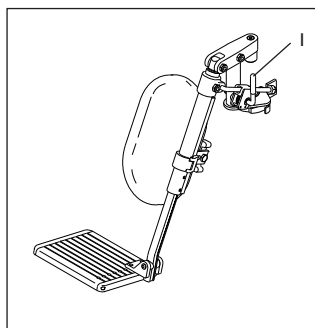

L. CASTER PLATES

(not available on the 500)

Note: Use a torque setting of 50-65 in./lbs. (5.6-7.3 N·m) when adjusting caster angle.

1. Angle Adjustment

- a. Loosen the two eccentric bolts that secure the caster assembly. Do not remove the clevis pin.
- b. Place a large right triangle against the table surface and the front surface of the caster bearing housing. This will align the caster stem rotational axis perpendicular to the floor surface.
- c. When alignment is satisfactory, retighten the two eccentric bolts.
- d. Repeat the process for the other.

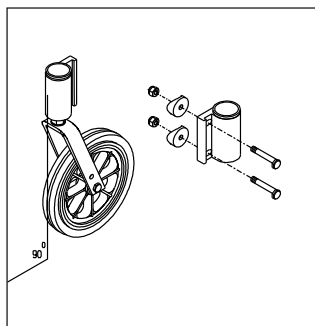

M. CASTER MOUNTING

- I. Forward or Rearward Placement
 - a. Remove caster housing covers.
 - b. Remove the two eccentric bolts from each caster.
 - c. Move left-side caster to right side.
 - d. Move right-side caster to left side.
 - e. Remount casters to caster bracket.

Note: Sunrise recommends mounting casters forward whenever possible.

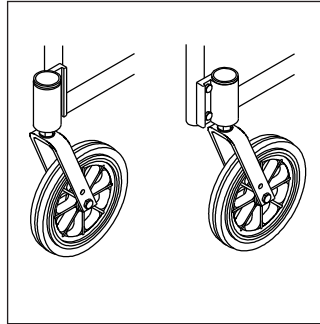

N. BACKREST

BREEZY 600

- I. Height Adjustment
 - a. Remove backrest material.
 - b. There are three holes, 1" apart, in each backrest tube (1). The tube telescopes into the frame and is secured by a bolt on the side of the frame. Choose one of the three holes to set the back height.
 - c. Remove bolt (2) from each backrest tube.
 - d. Choose the proper height. Slide the upholstery back on.

Note: Do not attach the overlap portion.

- e. Attach tab (3) to bolt (2) and tighten nut (4).
- f. Insert nylon tie (5) through grommets (6). Secure tie and cut off excess nylon.

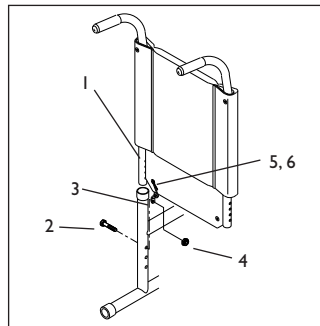

X. SET UP & ADJUSTMENT NOTES

XI. TROUBLESHOOTING

You will need to adjust your chair from time to time for best performance (especially if you alter the original settings). This chart gives you a first solution, then a second and a third if needed. You may need to look farther to find the best solution for a specific problem.

Note: To keep track of your progress, make only ONE change at a time.

Symptom	Left turn in chair	Right Turn in chair	Looseness in chair	Sluggish turning	Squeaks and rattles	Caster flutter	Solution
	<input checked="" type="checkbox"/>						Make sure tire pressure is correct and equal in both rear tires and front caster tires, if pneumatic.
			<input checked="" type="checkbox"/>	<input checked="" type="checkbox"/>	<input checked="" type="checkbox"/>	<input checked="" type="checkbox"/>	Make sure all nuts and bolts are tight.
			<input checked="" type="checkbox"/>		<input checked="" type="checkbox"/>		Make sure all spokes and nipples are tight on radial spoke wheels.
					<input checked="" type="checkbox"/>		Use Tri-Flow Lubricant (Teflon®-based) between frame connections and parts.
	<input checked="" type="checkbox"/>	<input checked="" type="checkbox"/>		<input checked="" type="checkbox"/>		<input checked="" type="checkbox"/>	Check for proper caster fork adjustment. See instructions for caster fork adjustment.

A. INTRODUCTION

1. Proper maintenance will improve performance and extend the useful life of your chair.
2. Clean your chair regularly. This will help you find loose or worn parts and make your chair easier to use.
3. Repair or replace loose, worn, bent or damaged parts before using this chair.
4. To protect your investment, have all major maintenance and repair work done by your authorized supplier.

⚠ WARNING

If you fail to heed these warnings your chair may fail and cause severe injury to the rider or others.

1. Inspect and maintain this chair strictly per chart.
2. If you detect a problem, make sure to service or repair the chair before use.
3. At least once a year, have a complete inspection, safety check and service of your chair made by an authorized supplier.

Weekly	3 Months	6 Months	Annually	Safety and Function Check
<input checked="" type="checkbox"/>				Tire integrity
<input checked="" type="checkbox"/>				Wheel locks
	<input checked="" type="checkbox"/>			Visually check for loose hardware
		<input checked="" type="checkbox"/>		Armrests
		<input checked="" type="checkbox"/>		Axle and axle sleeves
	<input checked="" type="checkbox"/>			Quick-release axles
	<input checked="" type="checkbox"/>			Wheels, tires and spokes
	<input checked="" type="checkbox"/>			Casters
	<input checked="" type="checkbox"/>			Anti-tip tubes
		<input checked="" type="checkbox"/>		Frame and crossbrace
	<input checked="" type="checkbox"/>			Upholstery
			<input checked="" type="checkbox"/>	Service by Authorized Supplier

NOTE - The user or caregiver should perform these weekly and monthly checks to maintain the safety of their chair. If an item is not working properly, please contact your authorized dealer.

B. MAINTENANCE

1. Axles & Axle Sleeves:

Check axles and axle sleeves every six months to make sure they are tight. Loose sleeves will damage the axle plate and will affect performance.

2. Tire Air Pressure:

Check air pressure in pneumatic tires at least ONCE A WEEK. The wheel locks will not grip properly if you fail to maintain the air pressure shown on tire sidewall.

D. CLEANING

1. Paint Finish

- a. Clean the paint finish with mild soap at least once a month.
- b. Protect the paint with a coat of non-abrasive auto wax every three months.

2. Axles and Moving Parts

- a. Clean around axles and moving parts WEEKLY with a slightly damp (not wet) cloth.
- b. Wipe off or blow away any fluff, dust, or dirt on axles or moving parts.
Note: You do not need to grease or oil the chair.

3. Upholstery

- a. Hand-wash (machine washing may damage fabric).
- b. Drip-dry only. DO NOT machine dry as heat will damage fabric.

E. STORAGE TIPS

1. Store your chair in a clean, dry area. If you fail to do so, parts may rust or corrode.
2. Before using your chair, make sure it is in proper working order. Inspect and service all items on the "Maintenance Chart." (See p. 45)
3. If stored for more than three months, have your chair inspected by an authorized supplier before use.

A. FOR LIFETIME

Sunrise warrants the frame and cross brace if applicable of this wheelchair against defects in materials and workmanship for the life of the original purchaser.

The expected life of this frame is five years.

B. FOR ONE (1) YEAR

We warrant all Sunrise-made parts and components of this wheelchair against defects in materials and workmanship for one year from the date of first consumer purchase.

C. LIMITATIONS

1. We do not warrant:
 - a. Tires and tubes, upholstery, pads and push-handle grips.
 - b. Damage from neglect, accident, misuse, or from improper installation or repair.
 - c. Products modified without Sunrise Medical's express written consent.
 - d. Damage from exceeding the weight limit.
2. This warranty is VOID if the original chair serial number tag is removed or altered.
3. This warranty applies in the USA only. Check with your supplier to find out if international warranties apply.
4. This warranty is not transferable and only applies to the first consumer purchase of this wheelchair through an authorized Sunrise Medical dealer.

D. WHAT WE WILL DO

Our sole liability is to repair or replace covered parts. This is the exclusive remedy for consequential damages.

E. WHAT YOU MUST DO

1. Obtain from us, while this warranty is in effect, prior approval for return or repair of covered parts.
2. Return the wheelchair or part(s), freight pre-paid, to:
Sunrise Medical
2842 Business Park Avenue,
Fresno, CA 93727-1328.
3. Pay the cost of labor to repair, remove or install parts.

F. NOTICE TO CONSUMER

1. If allowed by law, this warranty is in place of any other warranty (written or oral, express or implied, including a warranty of merchantability, or fitness for a particular purpose).
2. This warranty gives you certain legal rights. You may also have other rights that vary from state to state.

Record your serial number here for future reference:



Sunrise Medical (US) LLC
2842 Business Park Ave. • Fresno, CA • 93727
USA (800) 333-4000
Canada (800) 263-3390

Manufactured under one or more of the following patents:
U.S. Patent # 5,062,677; 5,149,173; 5,211,446; 5,352,023; 5,407,248; plus other foreign patents

© 2015, Sunrise Medical 10.15
930300 Rev. E